



The 17.5" HD-ready ASL 175 AeroScreen

General Specifications

Video

Composite	1.0V p-p into 50 ohm balanced
S/N	45db or better
Resolution	500 lines or better

Size

Dimensions	450mm W x 286mm H x 76mm D
Screen size	17.5 inches
Weight	6kg

Power Supply

Voltage	85VAC to 265VAC
Nominal Power	< 30 Watts

AC Frequency

45Hz to 440Hz auto-ranging

Cooling

No external cooling required

Operating Temperature Range

Nominal	-5°C to + 55°C (passive cooling)
---------	-------------------------------------

For further information call +44 (0)161 495 6951
 email ife@airline-services.com
 or visit www.airline-services.com/ife



ASL 175 AeroScreen Unit

Functionality and Technical Specification

Last Modified 24th February 2010

17.5", HD-ready, LCD Monitor designed for maximum viewing angle, brightness and colour, minimal power usage, reduced weight, ease of installation and maintenance, high reliability and interchangeability between bulkhead and centre-aisle retraction mountings.

Functionality

Usage

- Display of Video content
- Display of Rolling Map Imagery
- Display of Pram Messages
- Display of Safety Briefing
- Display of Advertising Material
- Centre-aisle Retract or Bulkhead Locations

Functions

- Remote control adjustments to all functions
- Fully automated with memory retention of settings
- Touch-sensitive bump strip
- Signal filtration included

Viewing Angle

The mechanism via the servo unit can adjust to allow the 90 degree (or vertical) position to be adjusted in two degree increments up to 130 degrees, providing for installation in different aircraft or cabin locations and to match the best passenger viewing angle. Also allows for the difference in the carpet thicknesses. The true measurement for the clearance is from the hard standing, but during fitment the likelihood is that the carpet will be in place. The required clearance of 73 inches is easily achieved.

Maintenance

Life Expectancy

Up to 100,000 Hours or in excess of 20 years due to carefully controlled CCFL drive unit. CCFL tubes being replaceable.

Protection

The protection screen is hard glazed on both sides to help prevent the abrasion marks from cleaning and is resistant to most known cleaning agents.

Line Replacement

Line replacement of monitors can be carried out in a matter of moments without the need to remove the entire retract assembly due to custom designed mounting plates on retract and bulkhead fittings.

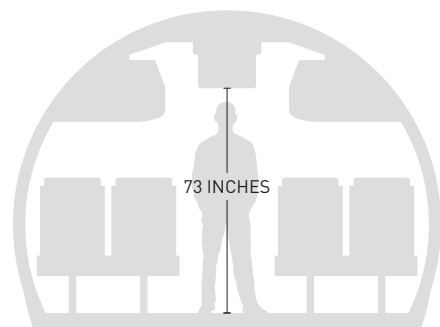
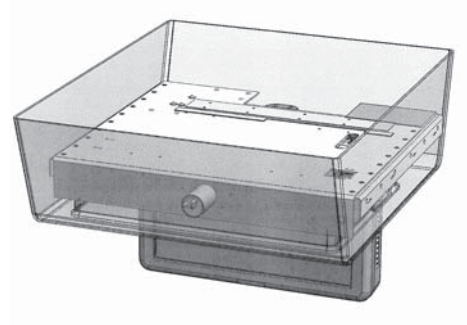

Power Requirements

Electrical

115Vac, 400Hz. Power Supply will operate from 85 Vac to 265 Vac @ 45Hz to 440Hz

Power Supply

Power supply meets and exceeds latest test requirements required under D0160 E/F. Hold up capacitors cover the change over in power from GPU to APU. Filtration built-in to front and back end of power supply to remove any unwanted surges or frequencies from the aircraft and prevent internally generated signals going back to the aircraft.

Power supply built-into AeroScreen Monitor Unit provides power for screen and the retract mechanism. In case of failure, replacement of the monitor will replace the majority of the electronics including the power supply.

Construction and Materials

Casing

LCD monitor case constructed from a resin moulding process to give maximum strength and fire safety. Forced ventilation via apertures surrounding case side and inner rear case. Monitor front case has fitted bump strip and will either stop or retract screen immediately upon sensing any impact.

Protection Screen

Viewing protection screen consists of 3mm Polycarbonate Aircraft grade. Sealed front and back to prevent fluid ingress. Assembly carried out in clean area with anti-static procedures in place.

Safety

Will stop if fouled on lowering or lifting, continuing its original trajectory some 10 seconds later if the foul is removed. Should the action on the lift or deployment be fouled three times, the monitor will lock up until reset by the cabin crew. The mechanism is driven down against a torsion spring which stores the energy necessary to return the monitor to a locked position when power is removed. If the power is removed the monitor returns to the closed position. The mechanism has a continual monitoring system checking the location of the monitor at all times.

The monitor locks up using a solenoid retainer. During a powered closure, the solenoid retracts immediately prior to the final closure of the monitor and then closes to mate up with a slot in the case of the monitor. In the case of a mechanical problem the retract can be manually returned and will be locked in place.



For further information call +44 (0)161 495 6951
email ife@airline-services.com
or visit www.airline-services.com/ife

